

SOLUTION OF WORLDWIDE SALES NETWORK

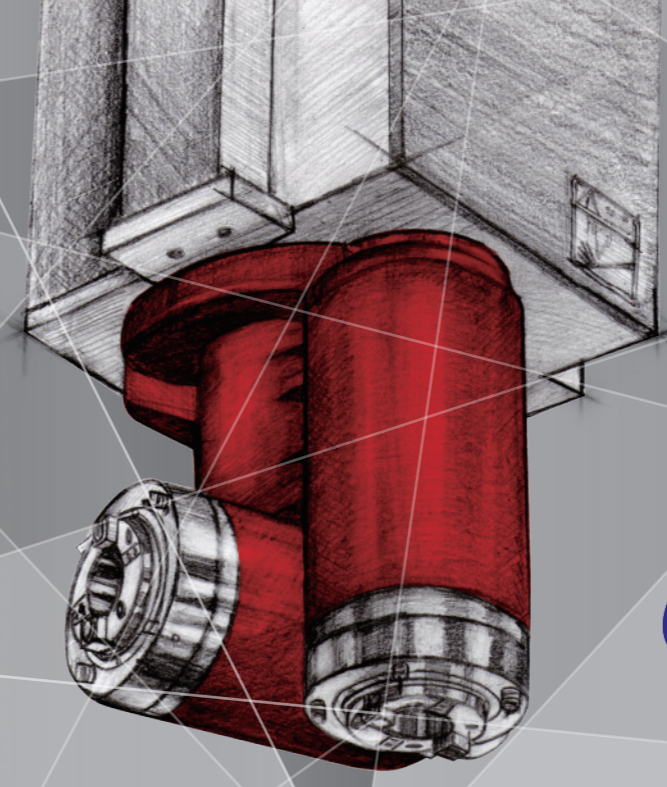

HELIOS

Series

5 Face Bridge Type Machining Center

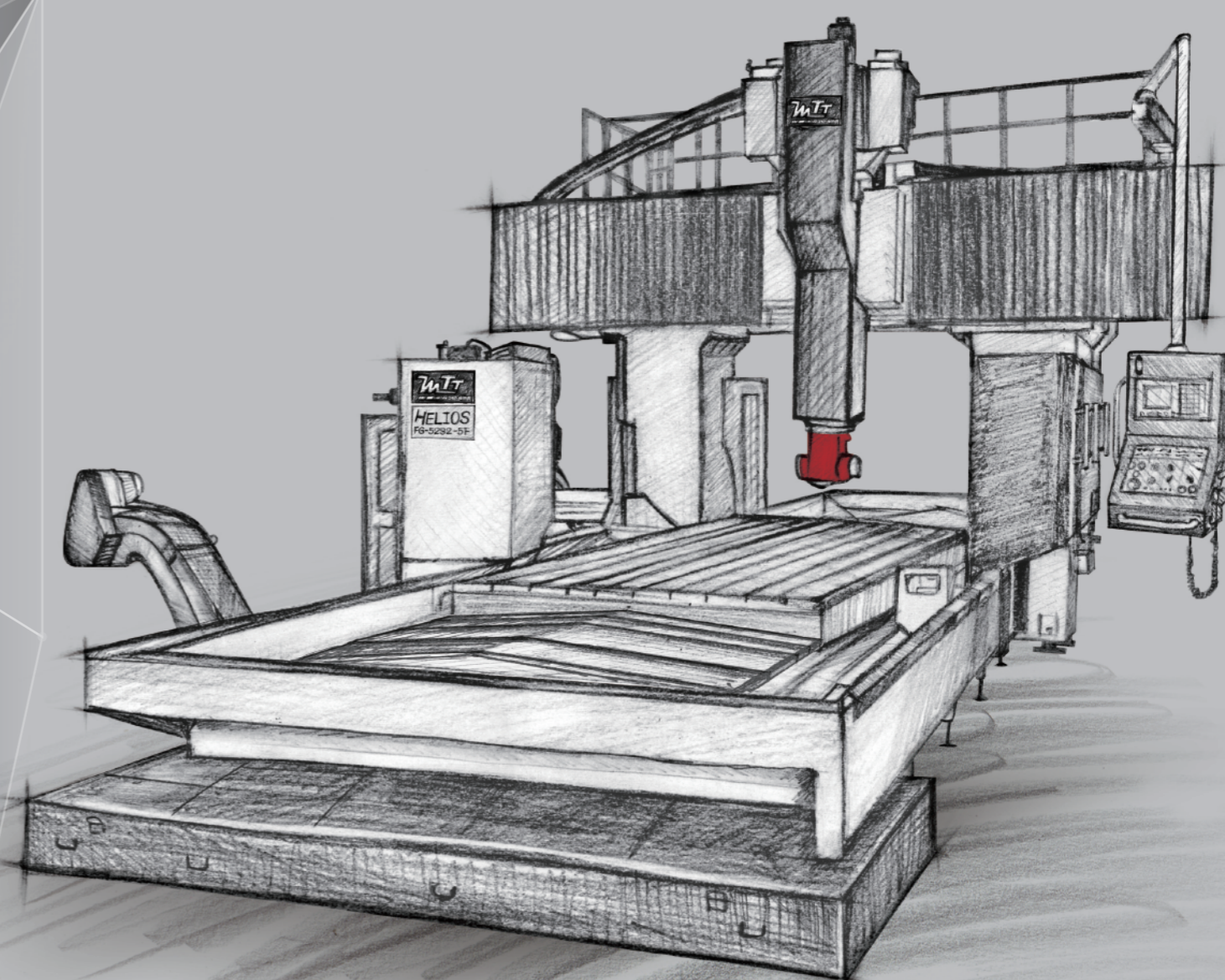

Twinhorn

CHI-FA MACHINERY MANUFACTURER CO., LTD.

No. 44-8, MING-CHUNG RD., SHENG-KANG DIST.,
TAICHUNG CITY, TAIWAN 42948
Tel: +886-4-2562-8747 (Rep.)
Fax: +886-4-2561-4199
E-mail: inquiry@twinhorn.com.tw
www.twinhorn.com



HELIOS Series

5 Face Bridge Type Machining Center

Widely used in various fields

- automotive industry, railway industry, shipbuilding industry
- Construction Machinery, petrochemical industry, aerospace industry
- Military Enterprise



◀ 5 Face Double Column
Machining Center-VIDEO

FG-5232-5F
Semi-enclosed splash guard

Combined vertical & horizontal milling head, Servo driven tool indexing to reduce tool changing time.

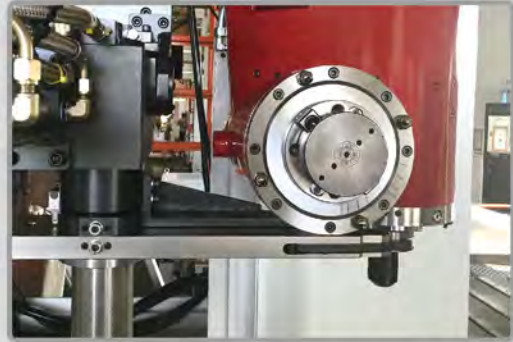

Vertical tool Change

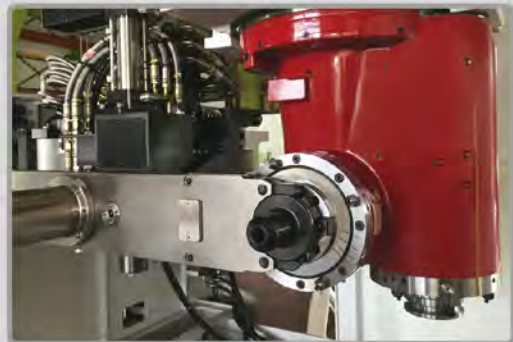

Horizontal tool Change

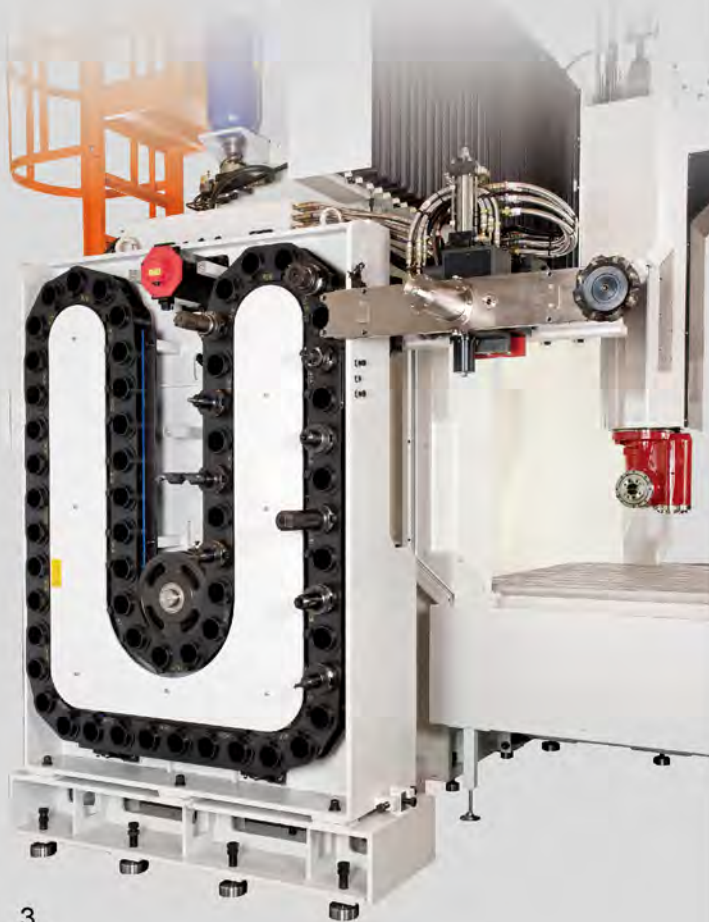

Structural characteristic



High rigidity cross-roller linear guides

X, Y, Z Axes adopts rigid, high-precision and smooth running guide ways. Multiple blocks and guide ways along the same axis enhance the static and dynamic loading capacity, thus guarantee accuracy and long service life.



High rigidity crossbeam structure design

The multi-layered steel column structure is specially reinforced and widened at the base to achieve the stability, rigidity and vibration damping characteristic required during high precision and high chip removal rate operations.

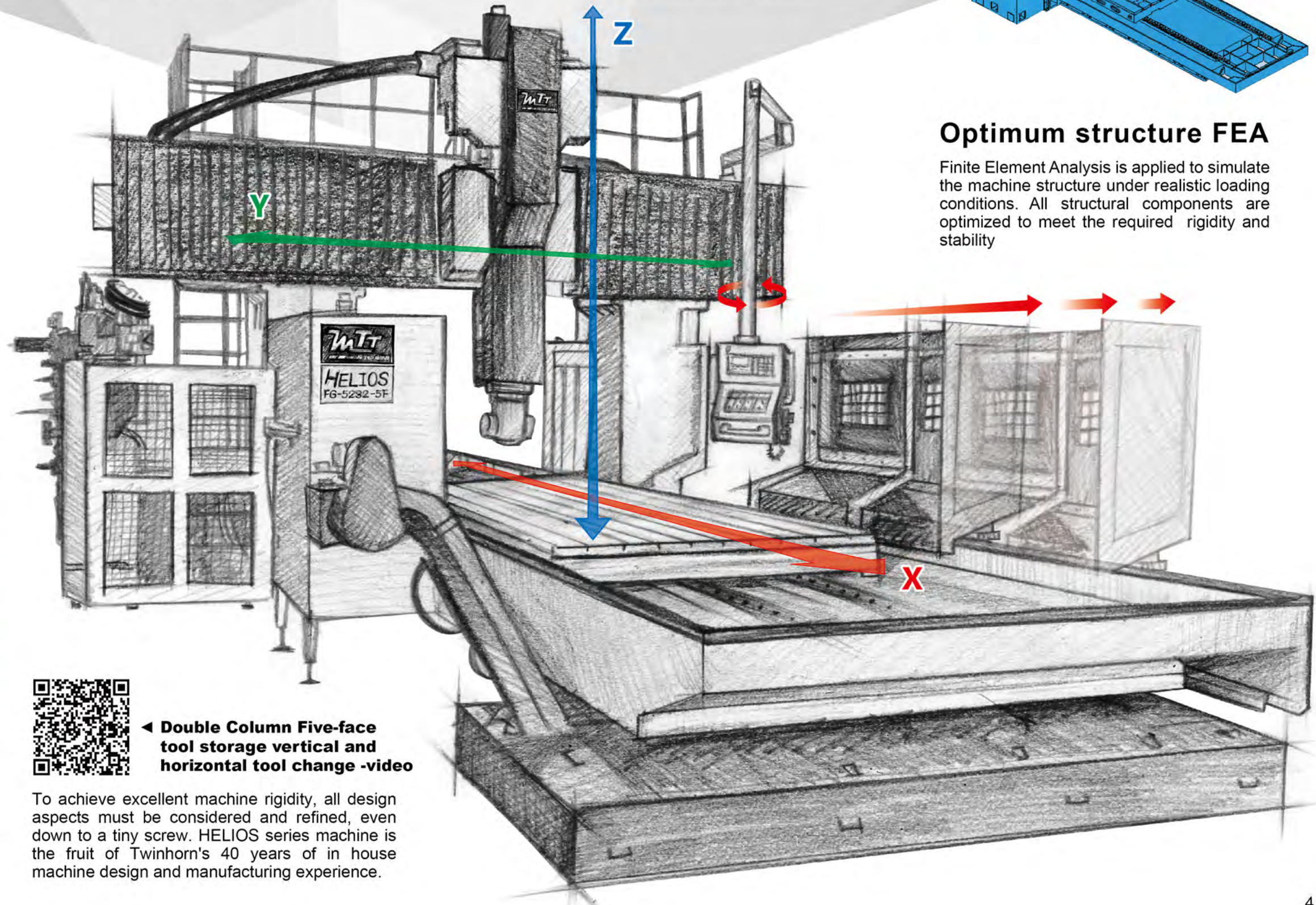
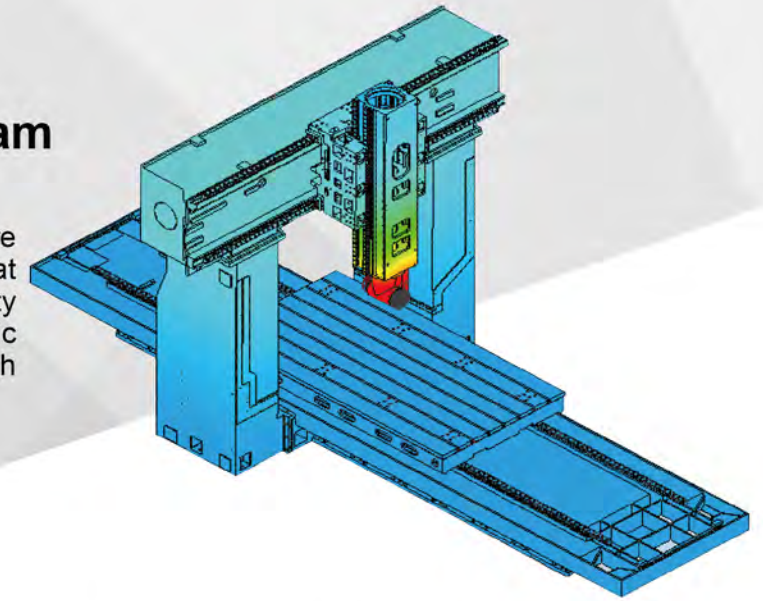

Optimum structure FEA

Finite Element Analysis is applied to simulate the machine structure under realistic loading conditions. All structural components are optimized to meet the required rigidity and stability



◀ **Double Column Five-face tool storage vertical and horizontal tool change -video**

To achieve excellent machine rigidity, all design aspects must be considered and refined, even down to a tiny screw. HELIOS series machine is the fruit of Twinhorn's 40 years of in house machine design and manufacturing experience.

HELIOS Series

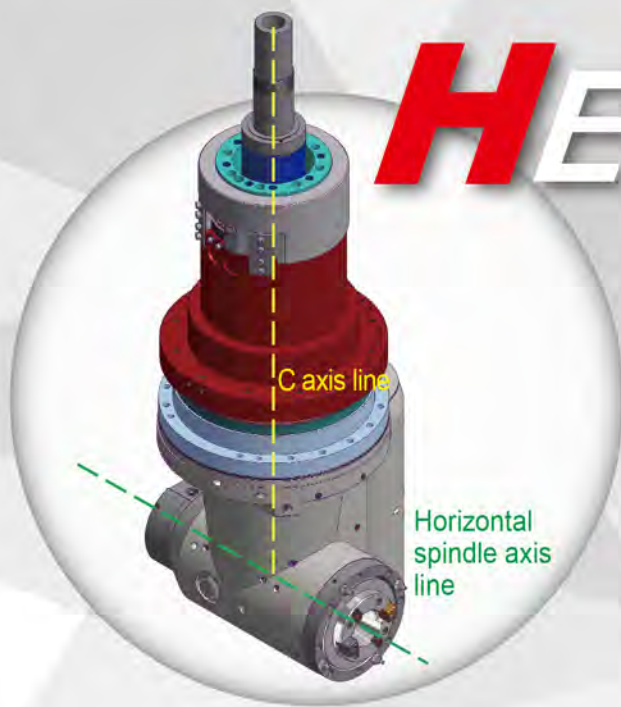

High performance five-face milling head

- Combined vertical & horizontal milling head, horizontal spindle center is aligned with C-ax center.
- C-axis rotating range ± 185 degree.
- C-axis positioning:
Standard: 5° indexed by spindle motor
Optional: 0.001° , independent index

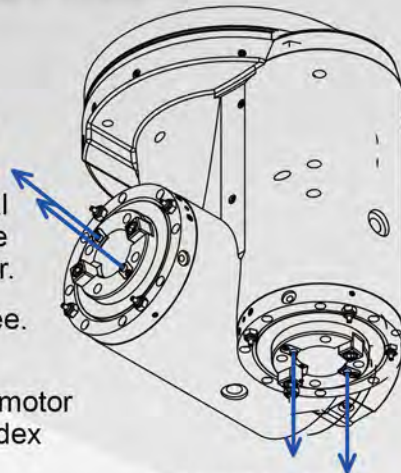

Schematic diagram of the coolant through center outlet

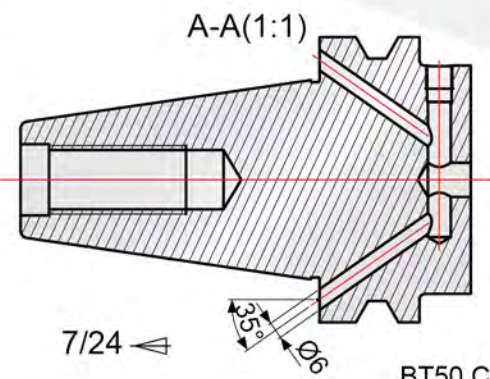

BT50 Coolant through tool holder type
DIN 69871 B Type

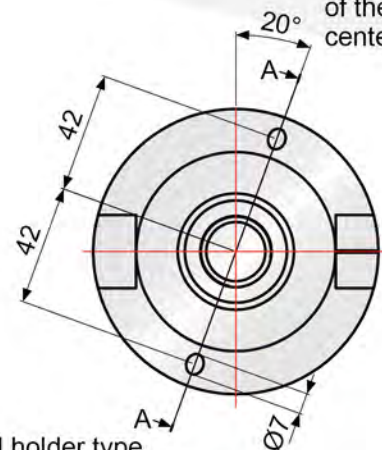

Machining capabilities

DRILING		FACE MILLING		TAPPING	
Cutting specification	Ø40 mm, HSS	Cutting specification	Ø160 mm Face mill cutter, Dry cut	Cutting specification	M30P3.5 spiral wire tapping (HSS)
Workpiece material	S45C (HRC 18°)	Workpiece material	S45C (HRC 18°)	Workpiece material	S45C (HRC 18°)
Spindle speed	253 rpm	Spindle speed	320 rpm	Spindle speed	200 rpm
Feed rate	101 mm/min	Feed rate	1250 mm/min	Feed rate	700 mm/min
Material removal rate	127 cc/min	Cutting width	135 mm	Tooth size	3.5 mm
Spindle load	80 %	Cutting depth	5 mm	Spindle load	38 %
		Material removal rate	844 cc/min		
		Spindle load	123 %		



5-axis milling head (TTFG1) 4-axis simultaneous

Sturdy, accurate, efficient adaptable design.

C-axis travel	$\pm 200^\circ$ 1470/3670 Nm
B-axis travel	$\pm 95^\circ$ 1470/3670 Nm
B-axis resolution	0.001° (index)
C-axis resolution	5° , opt. 0.001° (cont.)
Spindle type	4000 rpm BT-50(DIN-50) Gear-driven
Spindle power (S1)	34 kw (380 V)
Spindle torque (S1/S6-40%)	860/1100 Nm



Universal milling Head (TT2i)

Simple, accurate and adaptable universal head.

B-axis travel	0~90°
C-axis travel	$\pm 185^\circ$, 1200/1700 Nm
B-axis resolution	2.5° (index), opt. 0.001° (index)
C-axis resolution	5° , opt. 0.001° (cont.)
Spindle type	5000 rpm BT-50(DIN-50) Gear-driven
Spindle power (S1)	37 kw (380 V)
Spindle torque (S1/S6-40%)	500/700 Nm(S1/S6-40%)



5-face milling Head (TT2S)

Rigidity being optimized while remaining slim.
Best suited for multiple face milling operation.

C-axis travel	$\pm 185^\circ$, 1200/1700 Nm
C-axis resolution	5° , opt. 0.001° (cont.)
Spindle type	4000 rpm BT-50(DIN-50) Gear-driven
Spindle power (S1/S3-25%)	18.5/30 kw (220 V)
Spindle torque (S1/S3-25%)	698/1130 Nm

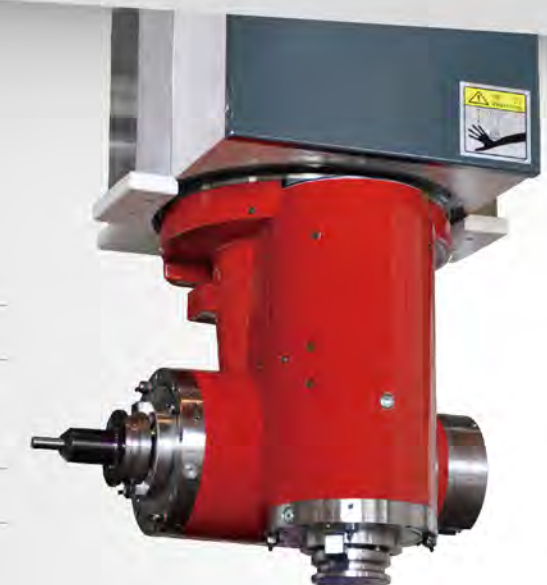

Vertical-horizontal head + C-axis Outline diagram

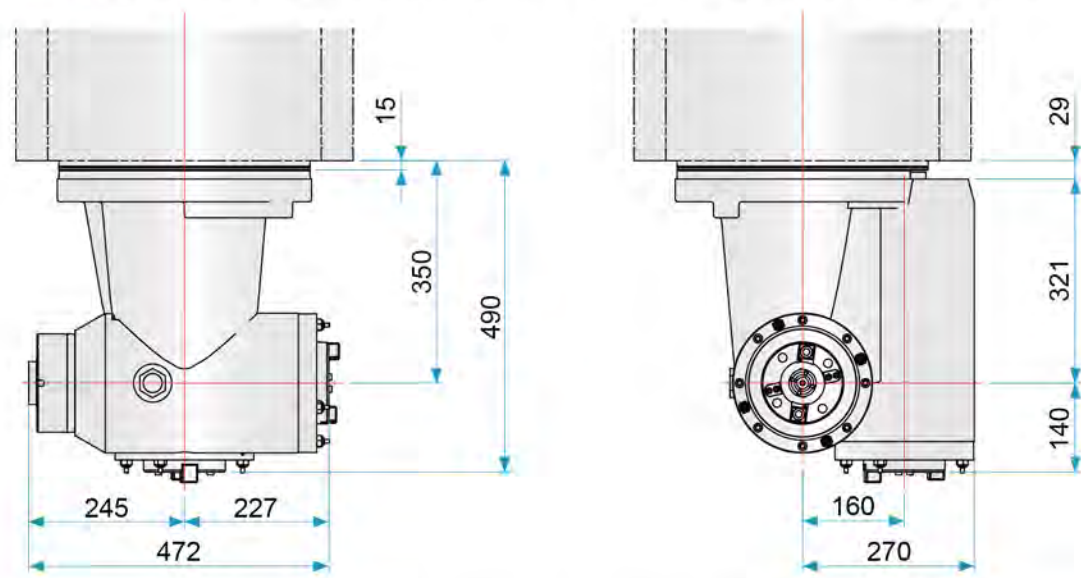

Output Power-Speed & Torque-Speed Characteristic



Pull Stud and Tool Shank dimensions

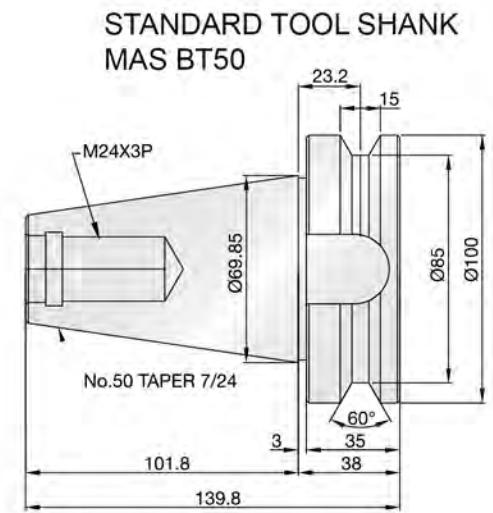

STANDARD PULL STUD MAS 403-P50T-1

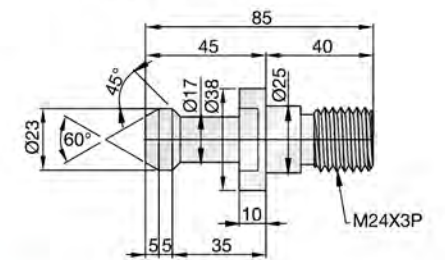

5 Face Bridge Type Machining Center external Dimension Chart

Dimension code	FG-3227/4227-5F	FG-4232/5232/6232-5F	FG-4237/5237/6237/8237-5F	FG-6242/8242-5F
A (X-axis travel)	3200/4200	4200/5200/6200	4200/5200/6200/8200	6200/8200
B (Y-axis travel)	2700	3200	3700	4200
C (Z-axis travel)	1000			
D (Table length)	3000/4000	4000/5000/6000	4000/5000/6000/8000	6000/8000
E (Table width)	1600	2000	2500	3000
F (Distance between two columns)	2000	2500	3000	3500
G (Maximum distance between horizontal spindle)	2246	2746	3246	3746
L (Machine length)	8990/11125	8990/11125/15000	8990/11125/15000/20000	15000/20000
W (Machine width)	5900	6450	6950	7500
H (Machine height)	5400	5450	5525	5600

Unit : mm

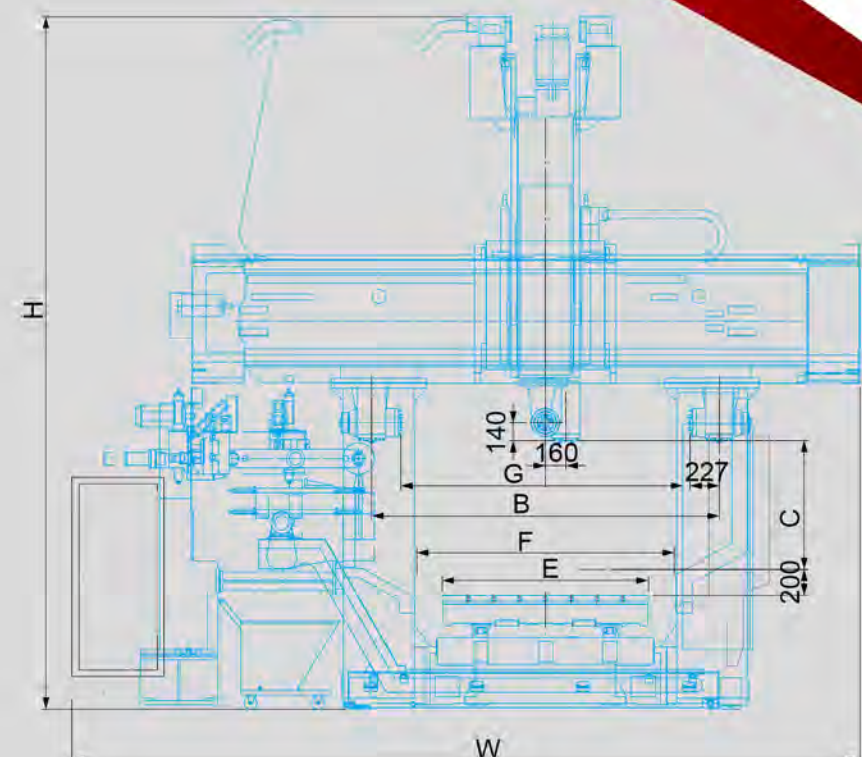
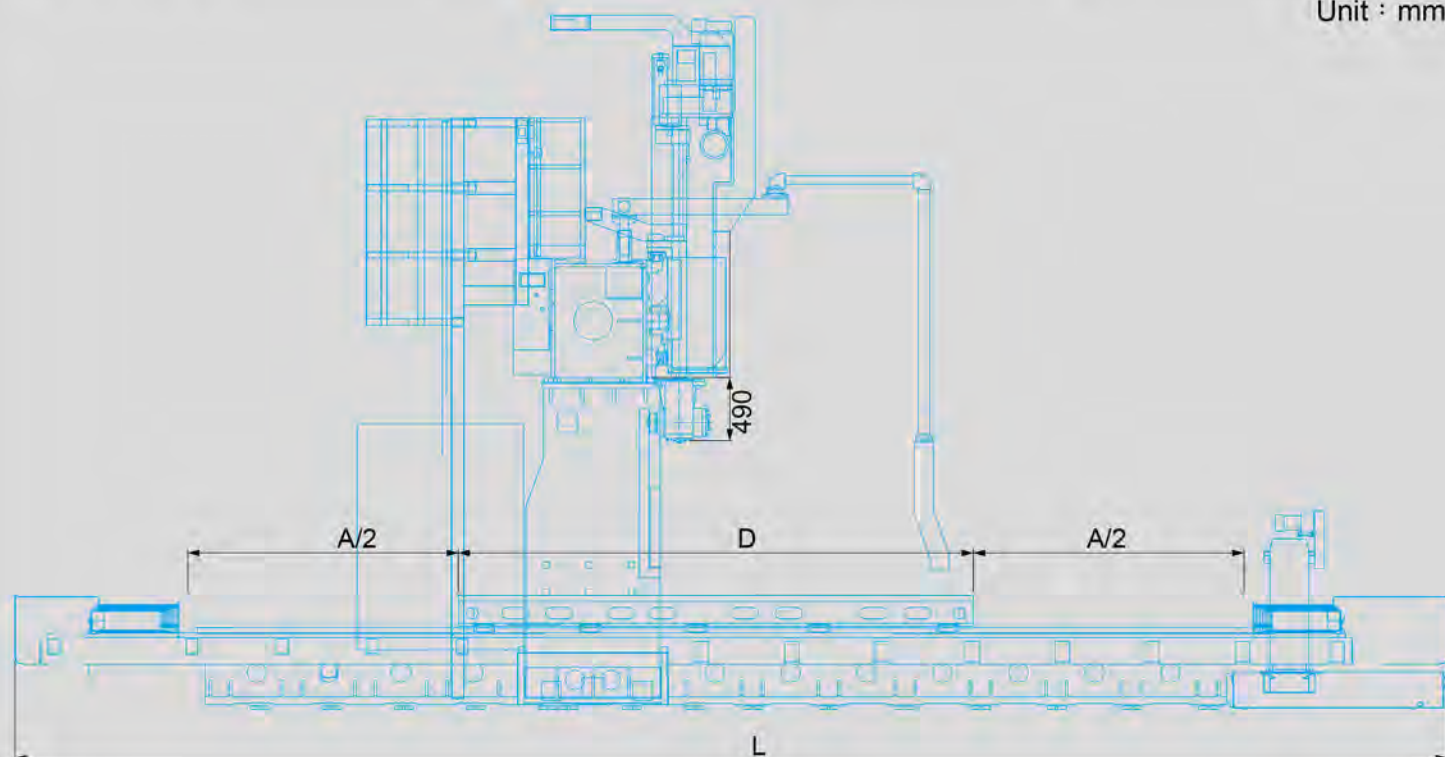

MACHINE SPECIFICATION

MODEL		FG-3227-5F	FG-4227-5F	FG-4232-5F	FG-5232-5F	FG-6232-5F	FG-4237-5F	FG-5237-5F	FG-6237-5F	FG-8237-5F	FG-6242-5F	FG-8242-5F	
Travel													
X-axis travel	mm	3200	4200	4200	5200	6200	4200	5200	6200	8200	6200	8200	
Y-axis travel	mm	2700		3200			3700			4200			
Z-axis travel	mm	1000						1000					
Vertical spindle nose end to worktable surface	mm	200~1200						200~1200					
Distance from horizontal spindle center end to worktable surface	mm	340~1340						340~1340					
Distance between two columns	mm	2000		2500			3000			3500			
Table													
Table size (X direction)	mm	3000	4000	4000	5000	6000	4000	5000	6000	8000	6000	8000	
Table size (Y direction)	mm	1600		2000			2500			3000			
T-slot (No. x size x distance)		7×22mm×200mm			9×22mm×200mm			9×28mm×250mm+2×28mm×150mm			11×28mm×250mm+2×28mm×150mm		
Max. Table load	kg	10000	12000	15000	18000	20000	18000	22000	25000	30000	30000	35000	
Spindle													
Spindle taper		BT50						BT50					
Spindle speed	min ⁻¹	4000						4000					
Spindle diameter	mm	90						90					
C axis rotation angle	deg.	±185°, 5°(index)						±185°, 5°(index)					
Feedrate													
Rapid feedrate (X/Y/Z)	m/min	15/15/10			12/15/10			15/15/10			12/15/10		
Cutting rate	mm/min	1-1000						1-1000					
Tool change													
Number of tool	pcs	60						60					
Max. tool diameter/ w./w.o. adjacent tool	mm	125/215						125/215					
Max. tool length	mm	400						400					
Max. tool weight	kg	20						20					
Pull stud		MAS403 P50T-1(45°)						MAS403 P50T-1(45°)					
Motor													
Spindle motor	kw	18.5/30(Cont./S3 25%)(oil18/7000)						18.5/30(Cont./S3 25%)(oil18/7000)					
Spindle max torque	N-m	1130(S3 25%)						1130(S3 25%)					
Feed motor X/Y/Z(FANUC)	kw	(F)6/7/7(A40/A30/A30B)						(F)6/7/7(A40/A30/A30B)					
Tool magazine motor	kw	4.0(α iF22B)						4.0(α iF22B)					
Cutting fluid pump motor	kw	2.6(50HZ)/4(60HZ)						2.6(50HZ)/4(60HZ)					
Accuracy(VDI/DGQ 3441)													
positioning accuracy P(X,Y,Z)	mm	0.025	0.030	0.030	0.035	0.040	0.030	0.035	0.040	0.050	0.040	0.050	
Repeatability accuracy Ps(X,Y,Z)	mm	0.020	0.025	0.025	0.030	0.035	0.025	0.030	0.035	0.045	0.035	0.045	
OTHER													
Power capacity		65 kVA, 200/220V, 3 phase 50/60Hz						65 kVA, 200/220V, 3 phase 50/60Hz					
Air pressure capacity		6kg/cm ²						6kg/cm ²					
Each axis guide		X 2 roller guide, Y 2 roller guide			X 3 roller guide, Y 2 roller guide			X 3 roller guide, Y 2 roller guide					
		Z Turcite & hardened box rail						Z Turcite & hardened box rail					
Machine dimension(L)	mm	8300	11000	11000	13000	15000	11000	13000	15000	20000	15000	20000	
Machine dimension(W×H)	mm	5900×5400			6450×5450			6950×5525			7500×5600		
Machine weight	kg	30000	35000	36000	41000	48000	46000	53000	60000	75000	62000	78000	

© The company reserves the right to change the mechanical specifications, accessories and appearance without prior notice.

Standard Accessories

- C-axis 5° (index)
- Half splash guard
- Y-axis bellows folding cover
- X-axis sheet metal telescoping cover
- Toolbox and tools
- Work light
- M30 Automatic power off
- signal light
- Leveling bolts and pads
- Spindle cooling system
- Coolant system
- Centralized lubrication system
- Electric cabinet heat exchanger
- Chip removal system and cart

Option Accessories

- Coolant through spindle
- Axes linear scale
- Auto tool length measurement device
- C-axis 0.001° (cont.)
- Auto workpiece measurement device
- Arm type magazine 80, 120 tools storage
- Electric cabinet air conditioner
- Transformer

Optional controller

- FANUC 0iMF
- SIEMENS 840Dsl
- MITSUBISHI M830S
- HEIDENHAIN TNC640